

## 2016-12 L-Band Downconverter

The 2016-12 L-band Downconverter converts 950 to 2150 MHz in 1 kHz, 10 kHz, or 125 kHz steps (user selectable) to 70 ± 18 MHz with low group delay and flat frequency response. Synthesized local oscillators (LO) provide very low phase noise and ±0.01 ppm stability frequency selection. Multi-function push button switches select the RF frequency, gain, and other parameters. Front panel LEDs provide indication of DC power (green), PLL alarm (red), and remote operation (yellow). Gain is adjustable manually over a 0 to +50 dB range as adjusted by the front panel multi-function push-button switches. Remote operation allows selection of frequency and gain. Parameter selection and frequency and gain settings appear on the LCD display. Connectors are BNC female for IF output and the optional external reference input and output, and Type F female for the RF input. LNB +24 VDC, 0.4 Amps and 10 MHz reference can be inserted on the RF line as added options. The 10 MHz option also includes a 10 MHz output connector, which contains either the internal or external 10 MHz reference signal. The unit is powered by a 90-260 VAC power supply, and housed in a 1 3/4" X 19" X 16" rack mount chassis.

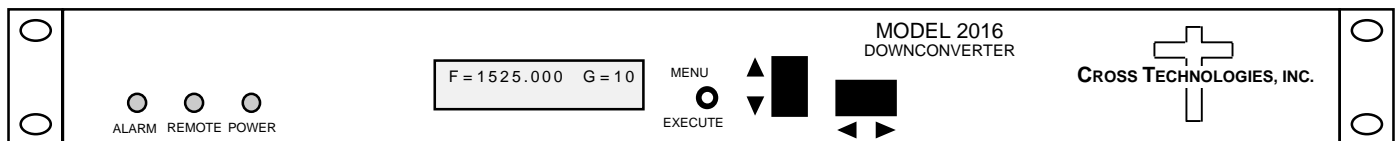

**2016-12 Downconverter Front Panel**

### EQUIPMENT SPECIFICATIONS\*

#### Input Characteristics (RF)

Impedance/Return Loss	75 Ω /12 dB
Frequency	950 to 2150 MHz
Noise Figure, max.	15 dB (max gain)
Input Level Range	-20 to -70 dBm
Input 1dB compression	-15 dBm

#### Output Characteristics (IF)

Impedance/Return Loss	75 Ω /18 dB
Frequency	70 ± 18 MHz
Output level/max linear	-20dBm / -10dBm
Output 1 dB comp.	-5 dBm

#### Channel Characteristics

Gain range (adjustable)	0.0 to +50.0 dB
Image Rejection	> 50 dB, min.
Frequency Response	±1.5 dB, 950 to 2150 MHz ; ± 0.5 dB, 36 MHz BW
Spurious Response	< -50 dBc, in band
Group Delay, max	0.01 ns/MHz <sup>2</sup> parabolic; 0.03 ns/MHz linear; 1 ns ripple
Frequency Sense	Inverting or Non-inverting, selectable

#### Synthesizer Characteristics

Frequency Accuracy	± .01 ppm
Frequency Step	1kHz, 10kHz, or 125kHz (user selectable)
Phase Noise (dBc/Hz)	< -75 @ 100Hz; < -90 @ 1kHz; < -97 @ 10kHz; < -107 @ 100kHz; < -120 @ 1 MHz
10 MHz Level (In or Out)	3 dBm, ± 3 dB, 75 ohms (option E)

#### Controls, Indicators

Frequency Selection	direct readout LCD; manual or remote selection
Gain Selection	direct readout LCD; manual or remote selection
Pwr; Alarm; Rem; Mute	Green LED; Red LED; Yellow LED; Red LED
Remote	RS232C, 9600 baud (RS485, option Q)

#### Other

RF Connector	Type F (female)
IF Connector	BNC (female)
10MHz Conn. (In or Out)	BNC (female)
Alarm/Remote Connector	DB9 (female) - NO or NC contact closure on Alarm
Size	19 inch, 1RU standard chassis 1.75"high X 16.0" deep
Power	90-260 VAC, 47-63 Hz, 45 watts max

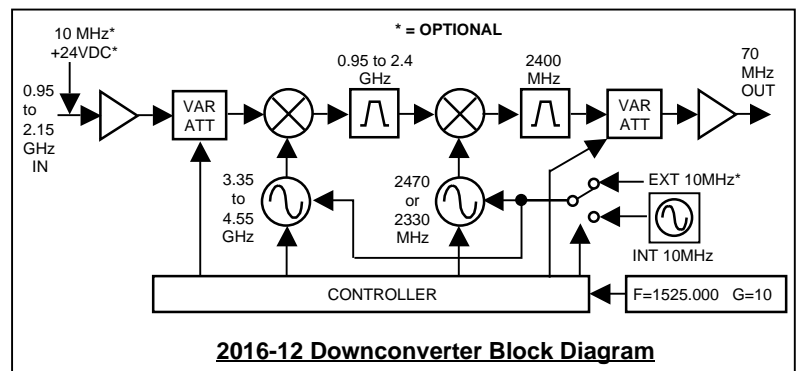

**2016-12 Downconverter Block Diagram**

#### Available Options

- E – External 10 MHz ref input & output w/ RF insertion
- L – LNB Voltage, +24VDC, 0.4 amps
- Q – RS485 Remote Interface
- T – Temperature Sensor
- Connectors/Impedance
- B – 75Ω BNC (RF), 75Ω BNC (IF)
- C – 50Ω BNC (RF), 75Ω BNC (IF)
- D – 50Ω BNC (RF), 50Ω BNC (IF)
- N – 50Ω N-type (RF), 75Ω BNC (IF)
- M – 50Ω N-type (RF), 50Ω BNC (IF)

\*+10°C to +40°C; Specifications subject to change without notice.