

2015-02 L-Band Upconverter

The 2015-02 L-band Upconverter converts 70 ± 18 MHz to 950 to 2150 MHz in 1 MHz steps with low group delay and flat frequency response. Synthesized local oscillators (LO) provide frequency selection. Multi-function push button switches select the RF frequency, gain, and other parameters. Front panel LEDs provide indication of DC power (green), PLL alarm (red), remote operation (yellow) or the TX carrier is muted (yellow). Variable attenuators for the IF input and output provide a gain range of -10 to +30 dB as adjusted by the front panel multi-function push-button switches. Remote operation allows selection of frequency and gain. Parameter selection and frequency and gain settings appear on the LCD display. Connectors are BNC female for IF and the optional external reference input and output, and Type F female for the RF output. SSPB +24 VDC, 2.5 Amps and 10 MHz reference can be inserted on the RF line as added options. The 10 MHz option includes a 10 MHz output connector which contains either the internal or external 10 MHz reference signal. A high stability (± 0.01 ppm) option is also available. The unit is powered by a 90-260 VAC power supply, and housed in a 3/4" X 19" X 16" rack mount chassis.

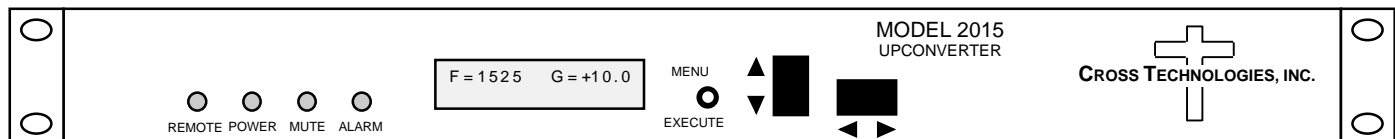

2015-02 Upconverter Front Panel

EQUIPMENT SPECIFICATIONS*

Input Characteristics (IF)

Impedance/Return Loss	75 Ω /18 dB
Frequency	70 ± 18 MHz
Input Level	-40 to -10 dBm

Output Characteristics (RF)

Impedance/Return Loss	75 Ω /12 dB
Frequency	950 to 2150 MHz
Output level	0 to -20 dBm
Output 1 dB comp.	+5 dBm

Channel Characteristics

Gain range (adjustable)	-10.0 to +30.0 dB
Frequency Response	± 1.5 dB, 950 - 2150 MHz ; ± 0.5 dB, 36 MHz BW
Spurious Response	< -50 dBc, in band
Group Delay, max	0.01 ns/MHz ² parabolic; 0.03 ns/MHz linear; 1 ns ripple
Frequency Sense	Non-inverting

Synthesizer Characteristics

Frequency Accuracy	± 1.0 ppm max over temp (± 0.01 ppm, option H)
Frequency Step	1.0 MHz (as low as 1 kHz steps available)
Phase Noise (dBc/Hz)	< -70 @ 100Hz, 1kHz; < -80 @ 10kHz; < -95 @ 100kHz; < -110 @ 1 MHz

10 MHz Level (In or Out) 3 dBm, ± 3 dB, 75 ohms (option E)

Controls, Indicators

Frequency Selection	direct readout LCD; manual or remote selection
Gain Selection	direct readout LCD; manual or remote selection
Pwr; Alarm; Rem; Mute	Green LED; Red LED; Yellow LED; Yellow LED
Remote	RS232C, 9600 baud (RS485, option Q)

Other

RF Connector	Type F (female)
IF Connectors	BNC (female)
10 MHz Conn. (In & Out)	BNC (female) (option E)
Alarm/Remote Connector	DB9 (female) - NO or NC contact closure on Alarm
Size	19 inch, 1RU standard chassis 1.75"high X 16.0" deep
Power	90-260 VAC, 47-63 Hz, 45 watts max

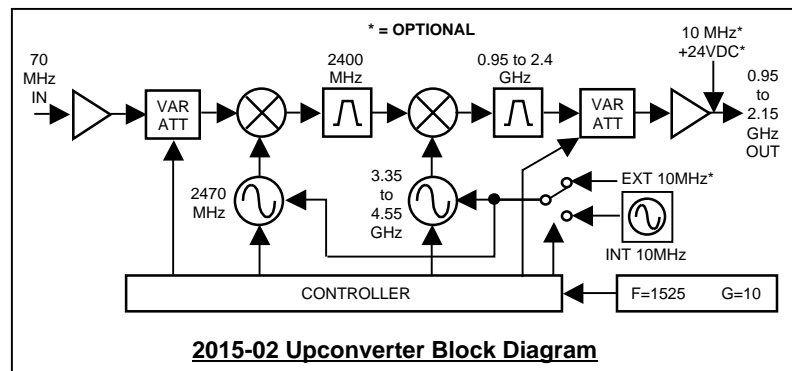

2015-02 Upconverter Block Diagram

Available Options

- E – External 10 MHz ref input & output w/ RF insertion
- H – High Stability (± 0.01 ppm) internal reference
- V – SSPB Voltage, +24VDC, 2.5 amps
- Q – RS485 Remote Interface
- T – Temperature Sensor
- Z – Attenuator 0.1 dB on Upconverter
- Connectors/Impedance
- B – 75 Ω BNC (RF), 75 Ω BNC (IF)
- C – 50 Ω BNC (RF), 75 Ω BNC (IF)
- D – 50 Ω BNC (RF), 50 Ω BNC (IF)
- N – 50 Ω N-type (RF), 75 Ω BNC (IF)
- M – 50 Ω N-type (RF), 50 Ω BNC (IF)

*+10°C to +40°C; Specifications subject to change without notice.