



Description

The Paradise Datacom Mini Compact Outdoor Solid State Power Amplifier (SSPA) is built for extreme environmental conditions and high reliability operation. Along with the robust construction exists the highest power density in the industry. This allows solid state technology to be used in applications that have long been reserved for TWTAs.

At less than 24.5 lbs. (11.2 kg), and only slightly larger than a lunch box, this family of SSPAs is available in the following output power levels:

C-Band: 75W, 100W, 175W
X-Band: 50W, 75W, 100W, 175W
Ku-Band: 50W, 80W

FEATURES

- Compact size and weight
- CE Compliance Tested
- Integrated forced-air cooling system
- Adjustable RF Gain, 55 dB to 75 dB
- Extreme Environmental Testing
- RF Output Sample Port
- Maintenance Free Operation
- Universal, Power Factor Corrected Power Supply
- Built-in 1:1 Redundancy Control
- Remote M&C via Serial or Ethernet
- Integrated Output Isolator for load VSWR protection

OPTIONS

- Extended band operation
- Antenna Mounting Kit
- Remote Control Panel
- L-Band Input
- FSK monitor & control via IFL
- Phase Combined Systems
- Fiber Optic Interface
- Optional side-mount AC input for SNG installations

SPECIFICATIONS

- Compact Outdoor housing
9.0 X 12.0 X 6.50 in
229 X 305 X 165 mm
- White powder coat finish
- Operating temperature:
-40 to +60 °C

CONTACT: www.servsat.com 770-754-4547 sales@servsat.com

Specifications

	PARAMETER	NOTES	LIMITS	UNITS
C-BAND	Frequency Range	(see options for extended band)	5.850 to 6.425	GHz
	Output Power @: Saturation/ P_{1dB} (Typical/Guaranteed minimum)	HPACC3075ACMXXXX HPACC3100ACMXXXX HPACC3175ACMXXXX	P_{sat} / P_{1dB} 48.8/48.5 (76/70) 50.0/49.5 (100/89) 1	dBm (W) dBm (W)
	Power Requirements Line Voltage Line Frequency Line Power	power factor corrected HPACC3075ACMXXXX HPACC3100ACMXXXX HPACC3175ACMXXXX	90 to 265 47 to 63 550 660 1	VAC Hz W W
	Extended C-Band 5.85 to 6.725 GHz	De-rate output power by 1.0 dB linearly from 6.425 - 6.725 GHz		
X-BAND	Frequency Range		7.900 to 8.400	GHz
	Output Power @: Saturation/ P_{1dB} (Typical/Guaranteed minimum)	HPAXX3050ACMXXXX HPAXX3075ACMXXXX HPAXX3100ACMXXXX HPAXX3175ACMXXXX	P_{sat} / P_{1dB} 47.0 / 46.5 (50 / 45) 48.8 / 48.3 (76 / 68) 50.0 / 49.5 (100 / 89) 1	dBm (W) dBm (W) dBm (W)
	Power Requirements Line Voltage Line Frequency Line Power	power factor corrected HPAXX3050ACMXXXX HPAXX3075ACMXXXX HPAXX3100ACMXXXX HPAXX3175ACMXXXX	90 to 265 47 to 63 465 600 710 1	VAC Hz W W W
	Transmit Band Filter (Option)	Insertion Loss	-0.5	dB
	Transmit Band Noise Power Density	Without optional filter With optional filter	-50 -120	dBm/4 KHz dBm/4 KHz
KU-BAND	Frequency Range	(see options for extended band)	14.00 to 14.50	GHz
	Output Power @: Saturation/ P_{1dB} (Typical/Guaranteed minimum)	HPAKU3050ACMXXXX HPAKU3080ACMXXXX	P_{sat} / P_{1dB} 47.0 / 46.0 (50 / 40) 1	dBm (W)
	Power Requirements Line Voltage Line Frequency Line Power	power factor corrected HPAKU3050ACMXXXX HPAKU3080ACMXXXX	90 to 265 47 to 63 665 1	VAC Hz W
	Extended Ku-Band 13.75 to 14.50 GHz	De-rate output power by 1.0 dB linearly from 14.00 - 13.75 GHz		

¹ See specification sheet 208838 for specifications of all GaN Mini Compact Outdoor amplifiers.

Common Electrical Specifications

PARAMETER	NOTES	LIMITS	UNITS
Gain	range	55-75	dB
Gain Flatness	full band (C-,X-,Ku-bands)	±1.0	dB
Gain Slope	full band (Extended C-Band)	±1.5	dB
Gain Variation vs. Temp.	per 40 MHz (C-,X-,Ku-bands)	±0.3	dB/40 MHz
Gain Adjustment	-40°C to +60°C 0.1 dB resolution	±1.5 20	dB dB
Intermodulation Distortion	Two-Tone 3 dB back off from P _{1dB}	-25	dBc
AM/PM Conversion	@ rated P _{1dB} @ P _{1dB} - 1 dB @ P _{1dB} - 2 dB	3.5 1.5 1.0	°/dB °/dB °/dB
Spurious (SSPA only)	(@ rated P _{1dB})	-60	dBc
Harmonics (SSPA only)	(@ rated P _{1dB} - 3 dB) (C-,X-,Ku-bands)	-50	dBc
Input/Output VSWR	All units except Extended C-Band Extended C-Band units	1.30:1 1.50:1	
Noise Figure	at maximum gain (C-,X-,Ku-bands)	10	dB
Group Delay (per 40 MHz segment)	Linear Parabolic Ripple	0.01 0.003 1.0	ns/MHz ns/MHz ² ns p-p
Transmit Band Noise	TX Band	-75	dBW/4 KHz
Output Power Density	RX Band (C-,X-,Ku-bands)	-150	dBW/4 KHz
Residual AM Noise	0 - 10 KHz 10 KHz - 500 KHz 500 KHz - 1 MHz	-45 -20 (1.25 + log F) -80	dBc dBc dBc
Phase Noise (SSPA only)	Offset frequency from carrier 10 Hz 100 Hz 1 KHz 10 KHz 100 KHz 1 MHz	-90 -100 -110 -120 -125 -130	dBc/Hz dBc/Hz dBc/Hz dBc/Hz dBc/Hz dBc/Hz
RF Power Detector	P _{sat} to (P _{sat} -20 dBm)	20 ± 1.0	dBm

Environmental Specifications

PARAMETER	NOTES	LIMITS	UNITS
Operating Temperature	Ambient	-40 to +60	°C
Relative Humidity	Condensing	100	%
Cooling System	Integrated, forced air	265	CFM
Altitude	No temperature de-rating up to 10,000 ft. (3000 m) De-rate maximum temperature by 2°C per 1,000 ft (300 m) beyond 10,000 ft.		
Shock	50 g p-p, 11 msec pulses		
Vibration	3g rms 30 min. 5-2000 Hz		

L-Band Operation

Paradise Datacom offers C-, X-, and Ku-Band amplifiers with an integrated L-Band Block Up Converter.

Available Frequency Plans

Band	Frequency Band	IF Input	LO Frequency	RF Output	Gain Change
C	Standard C-Band	950 - 1525 MHz	4.900 GHz	5.850 - 6.425 GHz	0-4 dB
C	Extended C-Band	950 - 1825 MHz	4.900 GHz	5.850 - 6.725 GHz	0-4 dB
X	Standard X-Band	950 - 1450 MHz	6.950 GHz	7.900 - 8.400 GHz	0-2 dB
Ku	Standard Ku-Band	950 - 1450 MHz	13.050 GHz	14.00 - 14.50 GHz	0-2 dB
Ku	Extended Ku-Band	950 - 1700 MHz	12.800 GHz	13.75 - 14.50 GHz	0-2 dB

Electrical Specifications for Mini Compact Outdoor with BUC

PARAMETER	NOTES	LIMITS				UNITS
Gain	Nominal setting	75				dB
Gain Flatness	full band (C-,X-,Ku-bands)	±2.0				dB
Gain Slope	per 40 MHz (C-,X-,Ku-bands)	±0.5				dB/40 MHz
Gain Adjusted Range		20				dB
Gain Stability	Typical Adj. Range -40 to +60 °C	55 - 75				dB
		±1.5				dB
Phase Noise	Offset frequency from carrier	<u>Absolute max.</u>	<u>C-band (typ.)</u>	<u>X-band (typ.)</u>	<u>Ku-band (typ.)</u>	
	10 Hz	-30	-60	-60	-50	dBc/Hz
	100 Hz	-60	-80	-75	-65	dBc/Hz
	1 KHz	-70	-80	-75	-72	dBc/Hz
	10 KHz	-80	-85	-100	-90	dBc/Hz
	100 KHz	-90	-120	-110	-110	dBc/Hz
	1 MHz	-90	-125	-122	-120	dBc/Hz
Spurious	In-Band Signal Related (C-/Ku-Band) (Extended C-Band)					-50 dBc
	Close to Carrier Spurious (≤ 20 MHz)					-50 dBc
	Local Oscillator					-30 dBm
	Non-Signal Related					-40 dBm
Noise Figure	At 75 dB gain setting					20 dB
Input VSWR	L-Band					1.5 : 1
Internal Reference Option	Reference accuracy @ 25 °C					±1 • 10 ⁻⁸
	Reference Stability over Temperature (-40 to +40 °C)					±1 • 10 ⁻⁹

Remote Control Panel - Ethernet Interface for the Mini Compact Outdoor SSPA



The RCP2-1000 is a Remote Control Panel for the Mini Compact Outdoor SSPA. It only requires 1RU of cabinet space and provides an identical local interface as exists on Paradise Datacom Indoor Rack Mount amplifiers.

The controller communicates with the outdoor amplifier via a RS485 link. The controller then provides a wide range of interface capability including Ethernet communications. The following communication links are available at the Remote Control Panel:

- RS232 or Addressable RS485 Serial Data
- Discrete (Parallel) Interface - Form C contact outputs & Opto Isolated Inputs
- Ethernet Interface - A full complement of Ethernet Communications including UDP, SNMP, and an internal web browser.
- Local (Manual) interface via front panel LCD display

Fiber Optic Interface

Paradise Datacom offers an Outdoor Fiber Optic Converter Module (OFM-1000) for the Mini Compact Outdoor SSPA which interfaces with a rack mountable Fiber Optic to L Band Transceiver (RCPF-1000).

The 1RU Indoor Fiber Optic to L Band Transceiver complements the Mini Compact Outdoor Amplifier for a complete Optical interface for the amplifier.

What distinguishes the Paradise Datacom Fiber Optic solution is the ability to transmit and receive not only the L-Band IFL, but also a 10 MHz reference signal and an FSK signal that provides complete remote control of the amplifier. When equipped with a Paradise Datacom Evolution Series PD25 L-B and modem, a complete baseband to optical interface is realized.

A system utilizing a Fiber Optic link can have an IFL length in excess of 1km. An optical link is also desirable in areas in which L-Band interference can degrade the system's performance.



**PD25 SATELLITE MODEM (top)
RCPF-1000 FIBER-OPTIC CONTROLLER**

**OFM-1000
EXTERNAL FIBER MODULE**

MINI COMPACT OUTDOOR SSPA



Mini Compact Outdoor Solid State Power Amplifiers in C-, X-, and Ku-Bands

Mechanical Specifications

PARAMETER	NOTES	LIMITS	UNITS/DETAILS
Size	width X length X height	9.0 X 12.0 X 6.50 229 X 305 X 165	inches mm
Weight (±3%)	Base unit	24.5 (11.2)	lbs. (kg)
Finish		Paint	White; powder coat
Connectors	RF Input RF Output - Ku-Band RF Output - C-Band RF Output - X-Band RF Output Sample Line Power Monitor and Control Link Port Redundancy Switch Auxiliary +15VDC LNB Power (500 mA)	Type N WR75 Waveguide WR137 Waveguide WR112 Waveguide Type N 3-pin MS-type 32-pin MS-type 6-pin MS type 6-pin MS-type 6-pin MS-type	Female Grooved flange (PBR-120) CPR137G flange (PDR-70) CPR112G flange (PDR-84) Female Plug Socket Socket Socket Socket

Part Number Configuration

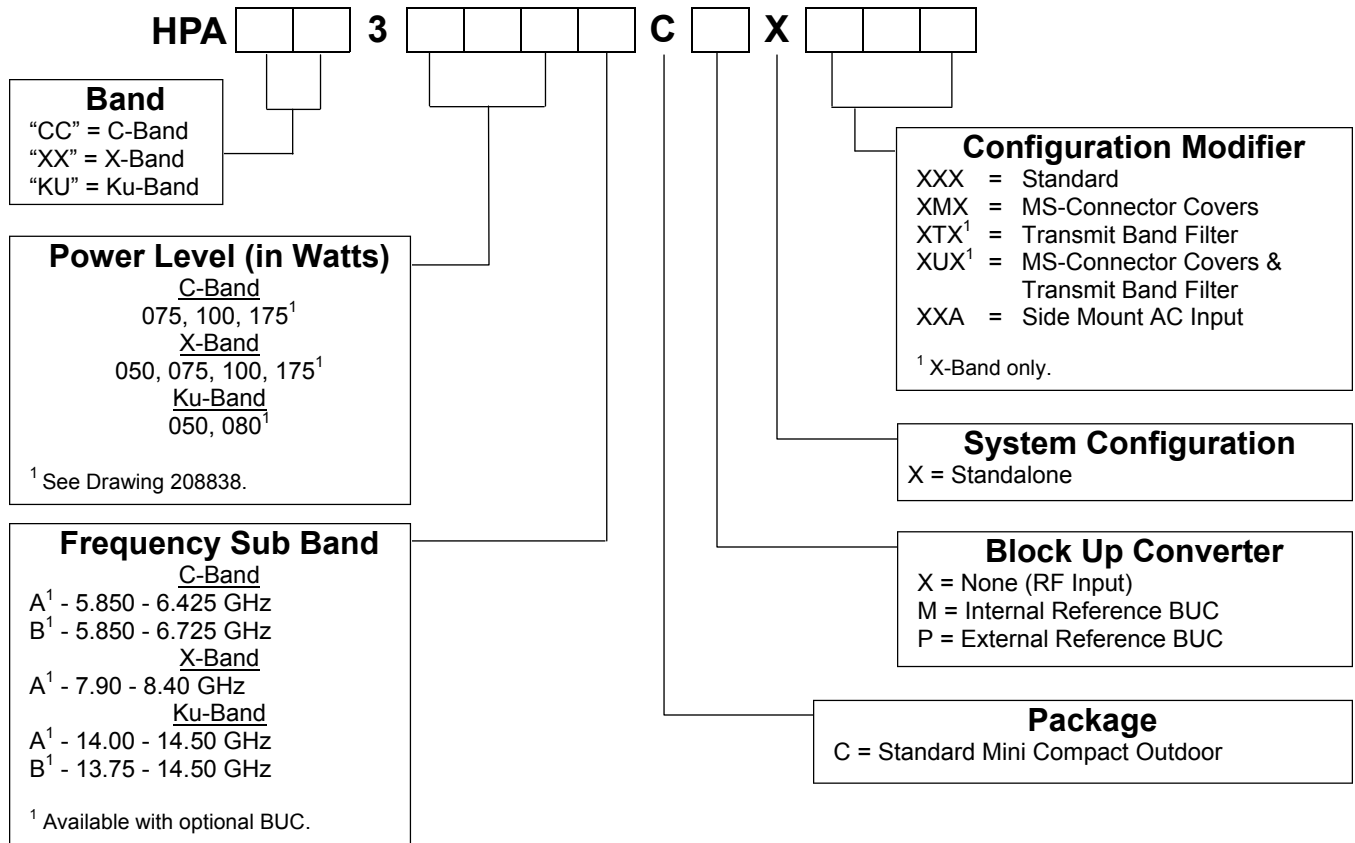

Example: A standalone 50W Extended Ku-Band Mini Compact Outdoor SSPA with an optional internal reference BUC and MS-Connector covers is part number: **HPAKU3050BCMXXMX**

Specifications listed in this document are subject to change without notice.
 X-band products may be subject to ITAR restrictions and should not be exported from the US without obtaining proper licensing from the appropriate government agencies.