



1/3 RACK-MOUNTED BLOCK CONVERTERS

BLOCK UPCONVERTERS

Input Frequency (GHz)	Output Frequency (GHz)	LO Frequency (GHz)	Model Number
0.95-1.525	5.85-6.425	7.375	UPB1-6.1TR-INV
0.95-1.75	5.85-6.65	4.9	UPB1-6.25TR
0.95-1.35	6.7-7.1	5.75	UPB1-6.9TR
0.95-1.45	7.9-8.4	6.95	UPB1-8.15TR
0.95-1.45	12.75-13.25	11.8	UPB1-13TR
0.95-1.7	13.75-14.5	12.8	UPB1-14.125TR
0.95-1.45	14-14.	13.05	UPB1-14.25TR
0.95-1.75	17.3-18.1	16.35	UPB1-17.7TR
0.95-2.05	17.3-18.4	16.35	UPB1-17.85TR*
0.95-1.25	18.1-18.4	17.15	UPB1-18.25TR

Ka-Band

0.95-1.2	28.35-28.6	27.4	UPB1-28.475TR
0.95-1.45	29-29.5	28.05	UPB1-29.25TR
0.95-1.2	29.25-29.5	28.3	UPB1-29.375TR
0.95-1.7	29.25-30	28.3	UPB1-29.625TR
0.95-1.95	30-31	29.05	UPB1-30.5TR*
1-2	30-31	29	UPB1-30.5-1TR*

*1 GHz IF Bandwidth.

BLOCK DOWNCONVERTERS

Input Frequency (GHz)	Output Frequency (GHz)	LO Frequency (GHz)	Model Number
3.4-4.2	0.95-1.75	5.15	DNB1-3.8TR-INV
3.4-4.2	0.95-1.75	8.55/11	DNB1-3.8TR
3.7-4.2	0.95-1.45	8.55/11.3	DNB1-3.95TR*
7.25-7.75	0.95-1.45	6.3	DNB1-7.5TR
10.7-11.7	0.95-1.95	9.75	DNB1-11.2TR*
10.95-11.7	0.95-1.7	10	DNB1-11.35TR
11.2-12	0.95-1.75	10.25	DNB1-11.6TR
11.45-12.25	0.95-1.75	10.5	DNB1-11.85TR
11.7-12.5	0.95-1.75	10.75	DNB1-12.1TR
11.7-12.75	0.95-2	10.75	DNB1-12.225TR*
12.2-12.75	0.95-1.5	11.25	DNB1-12.475TR
12.25-12.75	0.95-1.45	11.3	DNB1-12.5TR

Ka-Band

18.3-18.8	0.95-1.45	17.35	DNB1-18.55TR
19.7-20.2	0.95-1.45	18.75	DNB1-19.95TR
20.2-21.2	0.95-1.95	19.25	DNB1-20.7TR*
20.2-21.2	1-2	19.2	DNB1-20.7-1TR*
28.3-28.8	0.95-1.45	27.35	DNB1-28.55TR
29.25-29.5	0.95-1.2	28.3	DNB1-29.375TR
29.25-30	0.95-1.7	28.3	DNB1-29.625TR

*1 GHz IF Bandwidth.



Unit shown with Option 17

This equipment is designed for applications where frequency translation is needed between L-band and the transponder frequency.

FEATURES

- Automatic 5/10MHz internal/external reference selection with a 0.1 Hz nominal bandwidth clean-up loop
- Gain control
- RF and L-band signal monitor ports (RF monitor not available with Ka-band units)
- Low phase noise
- Low intermodulation distortion
- High frequency stability
- Summary alarm
- Mute function on alarm or external mute input command
- LO frequency and power monitor
- CE Mark

OPTIONS

- High performance package
- Higher frequency stability
- RS422/RS485 and 10/100Base-T Ethernet
- LO level monitor
- Lower gain

Patent Pending



SPECIFICATIONS

INPUT CHARACTERISTICS

Return loss (50 ohms).....	18 dB minimum (upconverters), 20 dB minimum (downconverters)
LO leakage	-80 dB maximum (downconverters)
Signal monitor	-20 dBc nominal

OUTPUT CHARACTERISTICS

Return loss (50 ohms).....	18 dB minimum (downconverters), 20 dB minimum (upconverters), 18 dB for units above 22 GHz
Signal monitor	-20 dBc nominal
Power output (1 dB compression).....	+13 dBm minimum (upconverters), +18 dBm minimum (downconverters)

TRANSFER CHARACTERISTICS

Gain	
Upconverters	30 dB, ± 3 dB at 23°C
Downconverters	35 dB, ± 3 dB at 23°C
Gain control	30 dB continuous adjust, rear panel control (0.2 dB steps with Option 17)
Gain stability	± 0.25 dB/day maximum at constant temperature
Amplitude response.....	± 0.25 dB/40 MHz maximum, ± 1 dB maximum over RF frequency band
Image rejection.....	60 dB minimum
Noise figure (at minimum attenuation)	15 dB maximum (20 dB for units above 22 GHz, 1 GHz IF bandwidth units)
Intermodulation distortion (third order)	With two inband signals at 0 dBm output, third order intermodulation products are less than 60 dBc minimum (downconverters) and 50 dBc minimum (upconverters, and all Ka-band units).
Spurious outputs (inband)	
Signal related.....	65 dBc minimum up to 0 dBm output (including 2x1 spurious on 1 GHz IF bandwidth units)
Signal independent.....	-75 dBm maximum
Phase noise.....	See graph
Frequency stability	$\pm 5 \times 10^{-8}$, 0 to 50°C (higher stability options available), 5×10^{-9} /day typical (fixed temperature after 24 hour on time)
Automatic reference configuration	External 5 or 10 MHz at +4 ± 3 dBm. If external reference is below +1 dBm nominal, the converter will automatically lock to the internal reference. Reference oscillator acts as an analog phase lock with a 0.1 Hz nominal loop bandwidth. Typical loop suppression of the external reference is as follows: 28 dB at 1 Hz offset; 65 dB at 10 Hz offset and 100 dB at 100 Hz offset
Mute	60 dB minimum on summary alarm or mute command. Mute status and control illuminated keys and LCD display with Option 17.

INDICATOR AND ALARMS

LO out-of-lock.....	Red LED (front panel)
Internal reference	Amber LED (front panel)
Power ON indicator	Green LED (front panel)
Summary alarm	Contact closure status for DC voltage and local oscillator

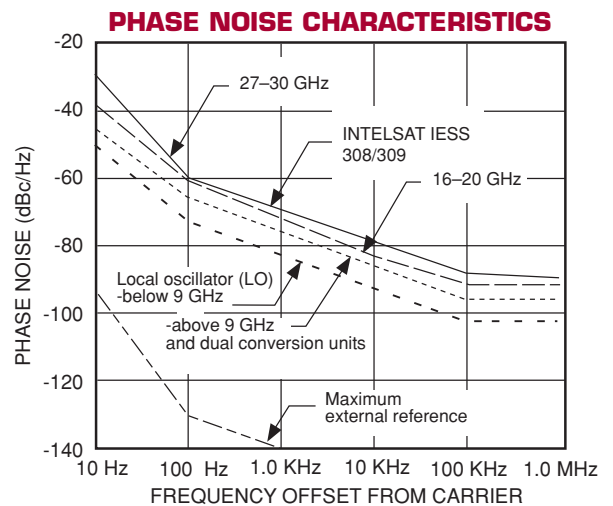

OPTIONS

- 1.** High performance package.
- Power output (1 dB compression) +20 dBm minimum (+15 dBm minimum, Ka-band upconverters)
- Gain slope..... 0.03 dB/MHz maximum
- Gain stability ± 0.25 dB/day maximum at constant temperature,
1.0 dB peak-to-peak maximum/0 to 50°C
- Group delay 1 ns peak-to-peak maximum
- Spurious outputs (inband)
- Signal related..... 65 dBc minimum at 0 dBm output
- Signal independent..... -80 dBm maximum
- Image rejection 80 dB minimum
- Intermodulation distortion (third order) With two inband signals at 0 dBm output, third order
intermodulation products are less than 60 dBc minimum and
50 dBc minimum (Ka-band upconverters).

High performance phase noise (dBc/Hz)(maximum)

	OFFSET (Hz)					
LO Frequency	10	100	1K	10K	100K	1M
Up to 6.7 GHz	-54	-78	-108	-116	-119	-136
6.7 GHz to < 8 GHz	-53	-76	-107	-114	-117	-134
8 GHz to < 12 GHz	-48	-73	-103	-112	-115	-132
12 GHz to < 13.4 GHz	-48	-72	-102	-110	-113	-130
13.4 GHz to < 16 GHz	-47	-70	-100	-108	-111	-128
16 GHz to < 24 GHz	-42	-67	-98	-106	-109	-126
24 GHz to < 29.05 GHz	-41	-64	-94	-102	-107	-124
Noise spectral density	-90 dBm/4 kHz maximum (upconverters below 18 GHz), -85 dBm/4 kHz maximum (downconverters and upconverters above 18 GHz)					
AM/PM conversion (at 0 dBm output)	0.1°/dB maximum					
Upconverter mute	80 dB minimum on summary alarm, external mute input control or remote command.					

- 2.** Lower gain.
- Gain 20 ± 3 dB at 23°C,
18 dB noise figure, 20 dB for 1 GHz IF bandwidth units,
signal related spurious -65 dBc at -5 dBm output.
- 8.** LO level alarm.
Summary alarm is generated for loss of power in any of the required local oscillators.
- 10.** Higher frequency stability reference.
- B.** $\pm 1 \times 10^{-8}$, 0 to 50°C,
1 $\times 10^{-9}$ /day typical (fixed temperature after 24 hour on time).
- C.** $\pm 5 \times 10^{-9}$, 0 to 50°C,
1 $\times 10^{-9}$ /day typical (fixed temperature after 24 hour on time).

Note: Converter may require 7-10 days to reach stability after long storage periods.

- 17.** Remote control 10/100Base-T Ethernet interface providing:
HTTP-based web server
SNMP 1.0 configuration
Alarm reporting via SNMP Trap
Telnet access
Password protection and selectable RS485/422
Gain control is 30 dB in 0.2 dB steps
Alarm, reference and mute status on front panel

Note: For literature describing local control (front panel) and remote control (bus control), refer to MITEQ's Technical Note 25T066. Missing option numbers are not applicable for this product.

1/3 RACK-MOUNTED BLOCK CONVERTERS

PRIMARY POWER REQUIREMENTS

Voltage	90–250 VAC
Frequency	47–63 Hz
Consumption	12 W typical

PHYSICAL

Weight	4.5 pounds (2.04 kg) nominal
Dimensions	5.70" [144.8mm] x 1.48" [37.6mm] x 18" [457.2mm] (excluding connectors)

Rear panel connectors

RF band.....	SMA female compatible
L-band	SMA female
RF band monitor	SMA female (not available with Ka-band units)
L-band monitor	SMA female
External reference input	SMA female
Status interface	DE-9S
Redundancy interface	DE-9P
Remote interface (Option 17).....	RJ-45 female for Ethernet, RS422/485 available on status connector
Primary power input	IEC-320

Front panel connectors

LO monitor.....	SMA female
-----------------	------------

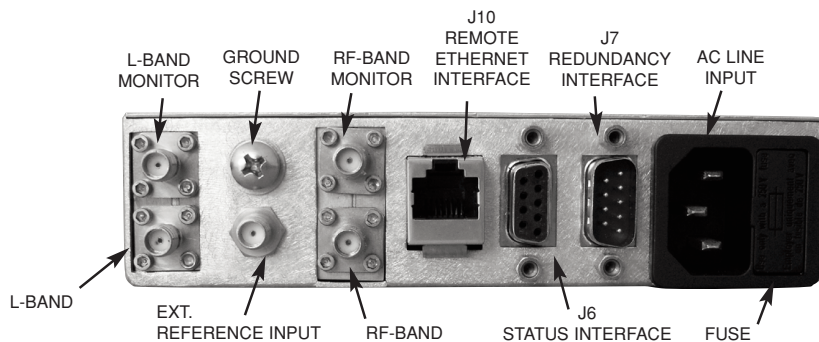

TYPICAL REAR
PANEL VIEW
(with Option 17)

ENVIRONMENTAL

Operating

Temperature	0 to 50°C
Relative humidity	Up to 95% at 30°C
Atmospheric pressure	Up to 10,000 feet

Nonoperating

Temperature	-50 to +70°C
Relative humidity	Up to 95% at 45°C
Atmospheric pressure	Up to 40,000 feet
Shock and vibration.....	Normal handling by commercial carriers

ACCESSORIES

Rack mount frame

Model number	OL-TR3-20
Weight	1.5 lbs. [0.68 kg] nominal
Dimensions.....	19" [482.6mm] x 1.75" [44.5mm] x 20" [508.0mm]

Single unit frame (includes rack slides)

Model number	OL-TR1-20
Weight	2 lbs. [0.9 kg] nominal
Dimensions.....	19" [482.6mm] x 1.75" [44.5mm] x 18" [457.2mm]